



EKIPA

0094NOTIC6101



FRANCE

DESSERTTE

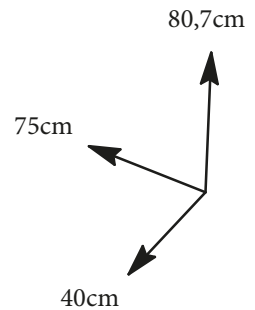
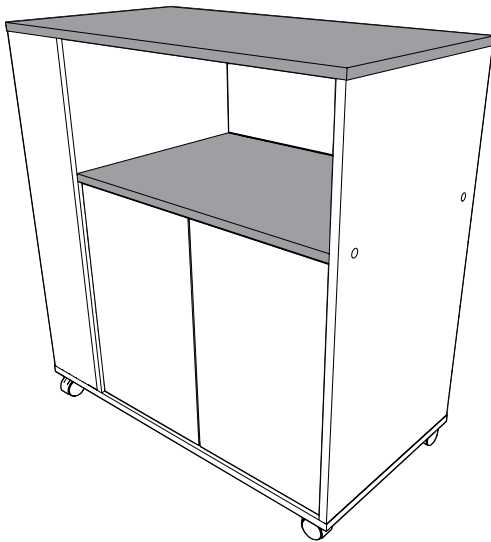

FR Remerciements :
Nous vous remercions d'avoir choisi un meuble créé et fabriqué par Ekipa et espérons qu'il vous donnera entière satisfaction.

EN Thanks :
Thank you for choosing furniture designed and manufactured by Ekipa. We hope you are totally satisfied your purchase.

ES Agradecimientos :
Les damos las gracias por haber elegido un mueble diseñado y fabricado por el Ekipa y esperamos que sea de su total agrado.

DE Danksagung:
Wir danken Ihnen für den Kauf eines Frankreich von der Ekipa entworfenen und hergestellten Möbelstücks und hoffen, dass Sie es zu Ihrer vollkommenen Zufriedenheit finden werden.



Temps de montage : 1h00



contact@parisot.com



Conseils de préparation au montage : 30 min

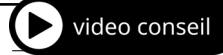

<https://qrco.de/bcJeNz>

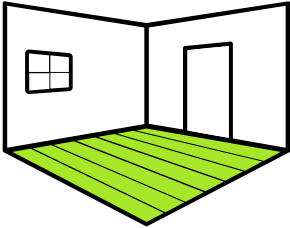

Faire un peu de place

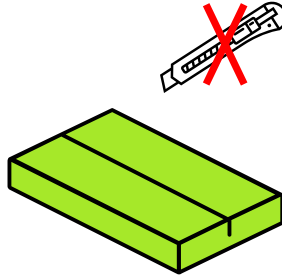

Pas d'outils tranchants

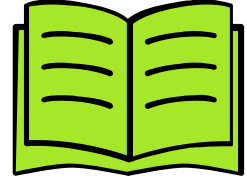

Bien suivre les instructions de la notice de montage

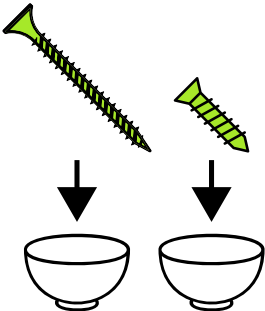

Trier vos quincailleries

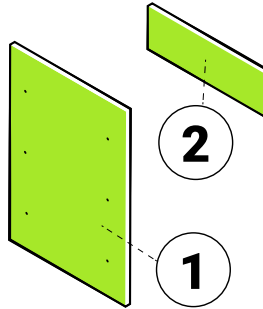

Repérer vos pièces

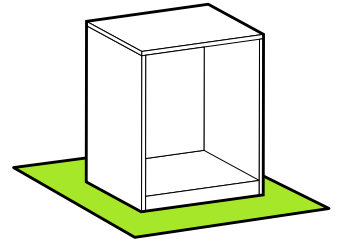

Protéger votre sol

Matériel nécessaire

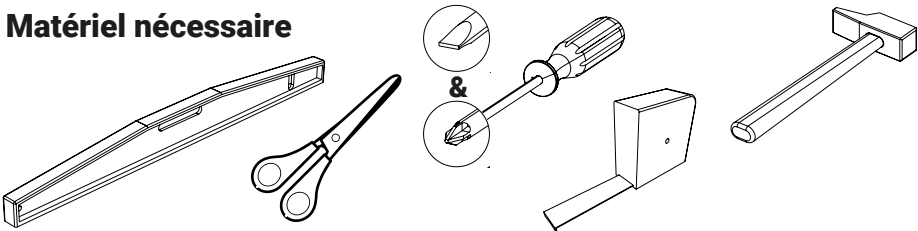

Conseils d'entretien

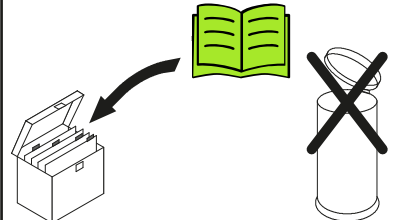

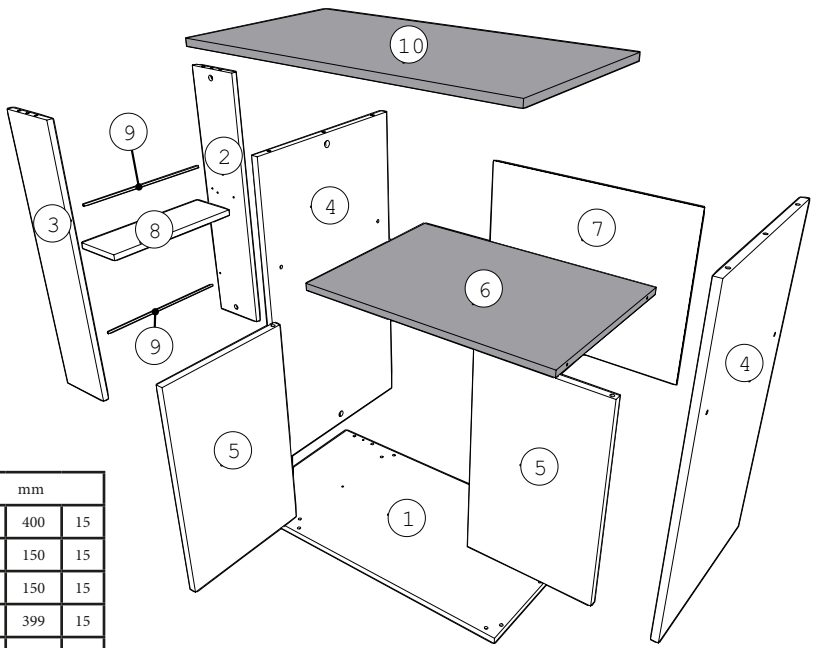

Rep	Qté	mm		
01	1	750	400	15
02	1	720	150	15
03	1	720	150	15
04	2	720	399	15
05	2	459	279	15
06	1	568	398	15
07	1	597	496	2,5
08	1	367	123,5	15
09	2	363	5	5
10	1	750	400	15

0 1cm 2 3 4 5

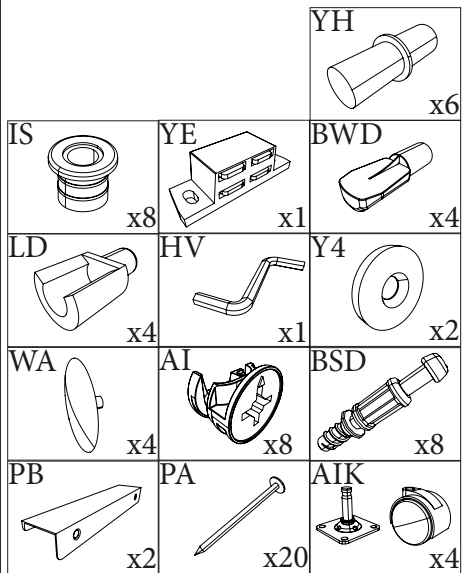
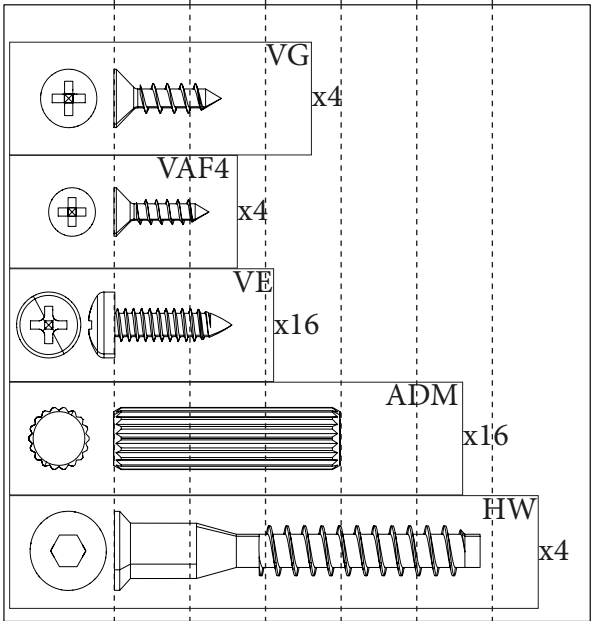

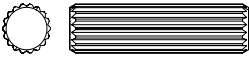

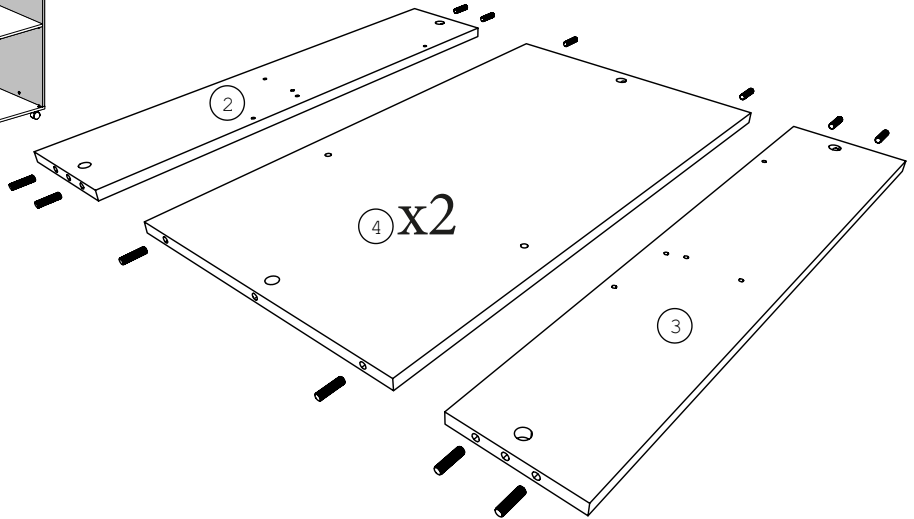
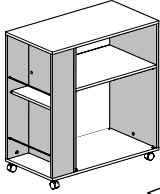
1  ADM
x16

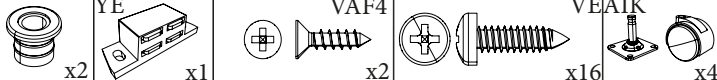

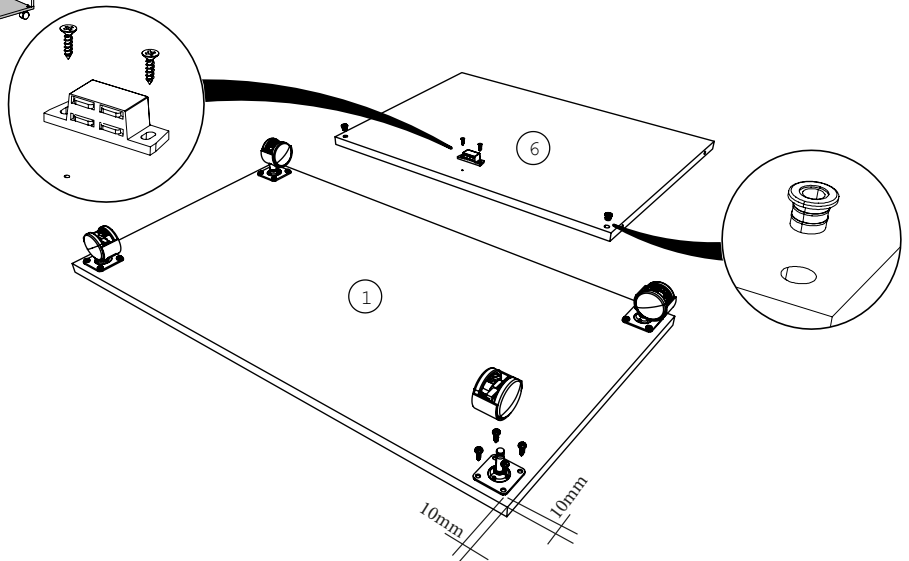
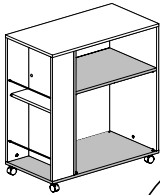

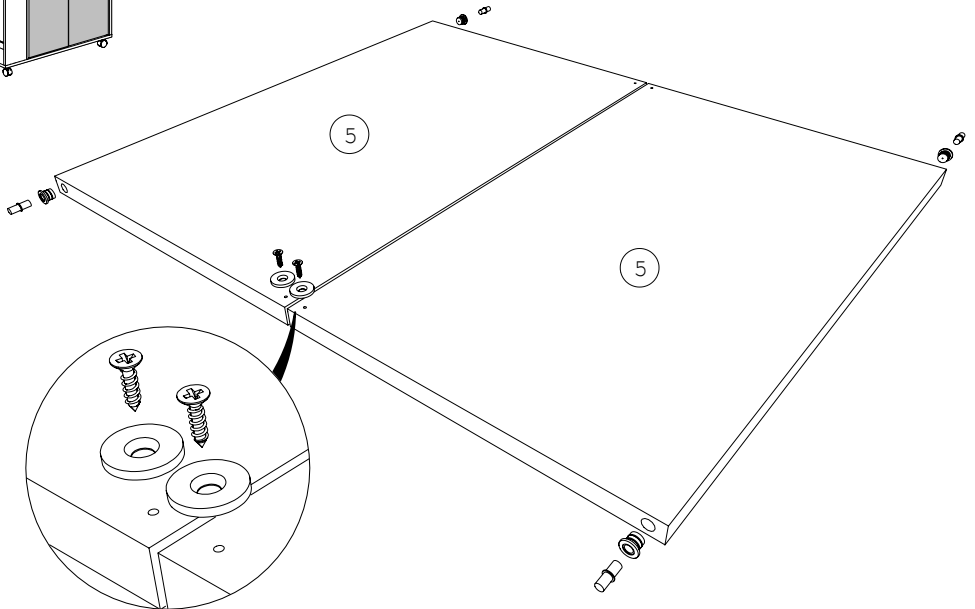
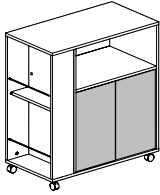
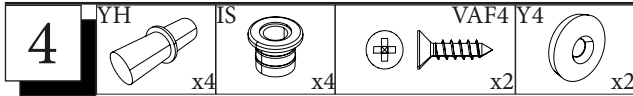
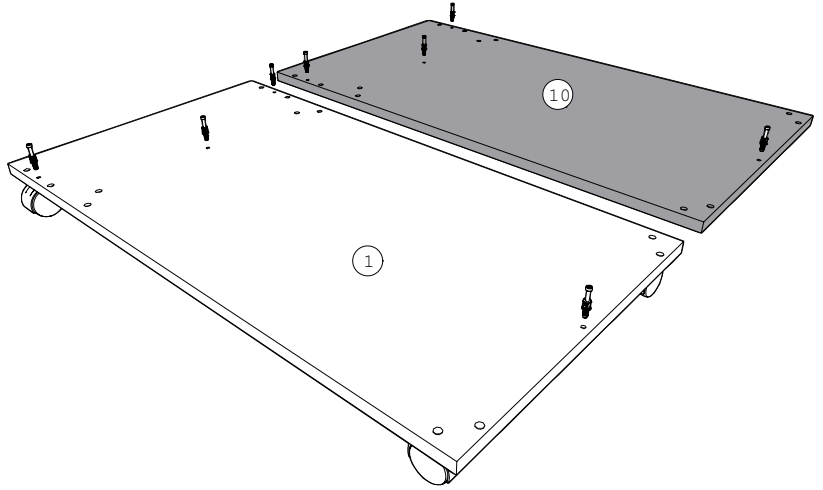
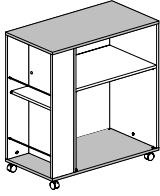
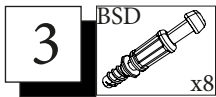
2  IS x2, YE x1, VAF4 x2, VEA1K x16, Nut x4



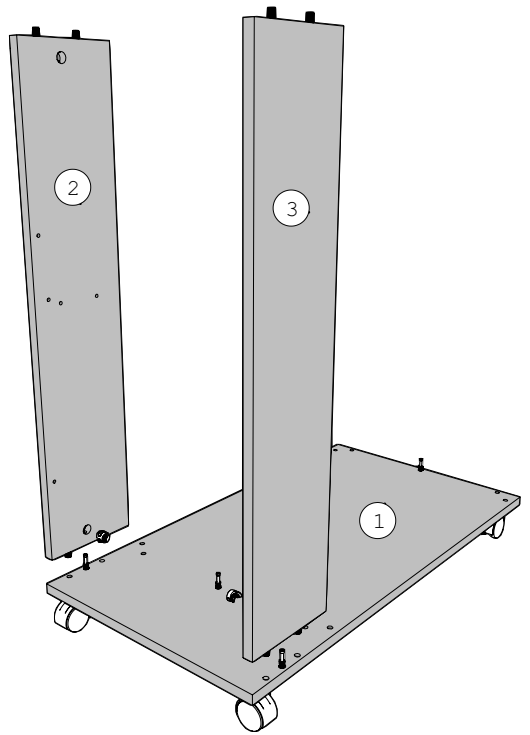
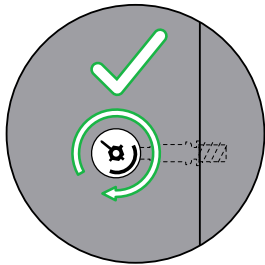
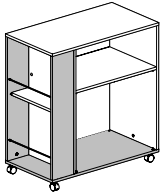

5   x2



6   x2

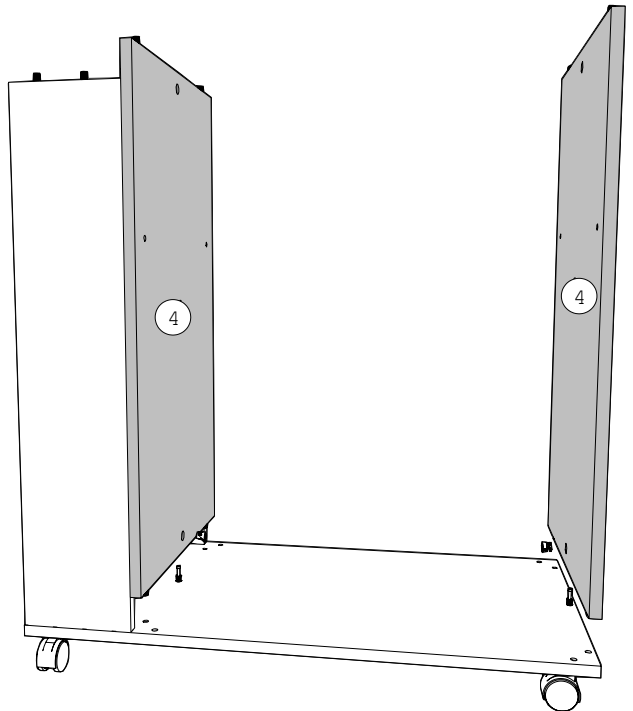
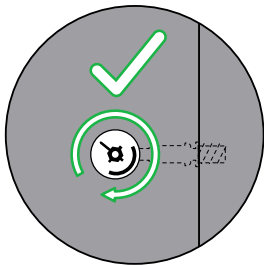
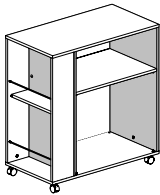

7

IS



x2

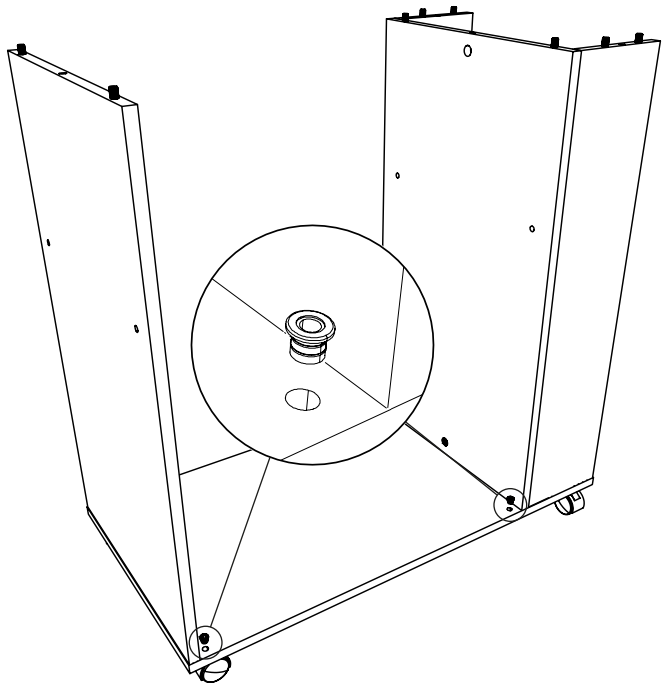
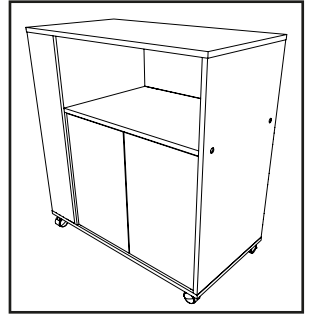
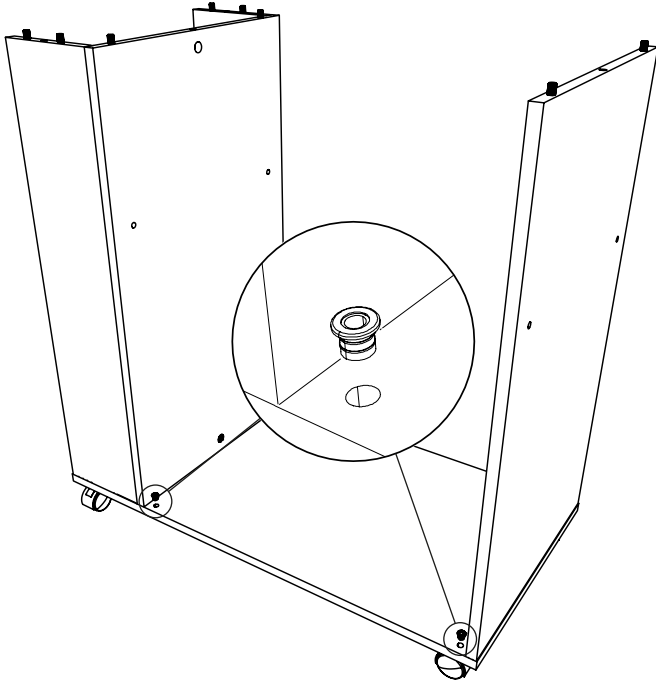

8

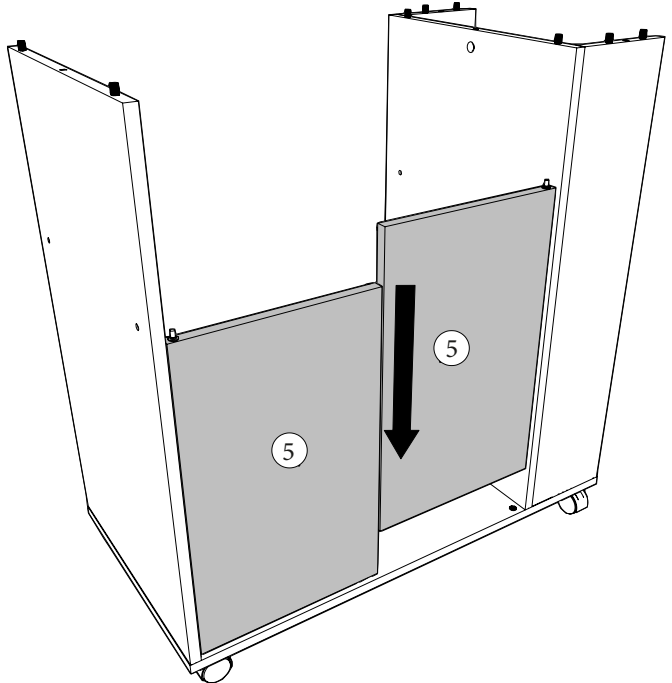
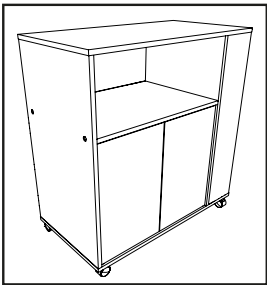
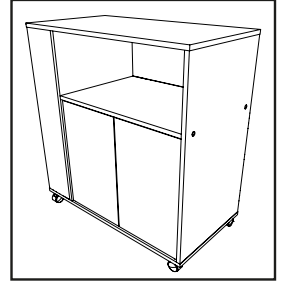
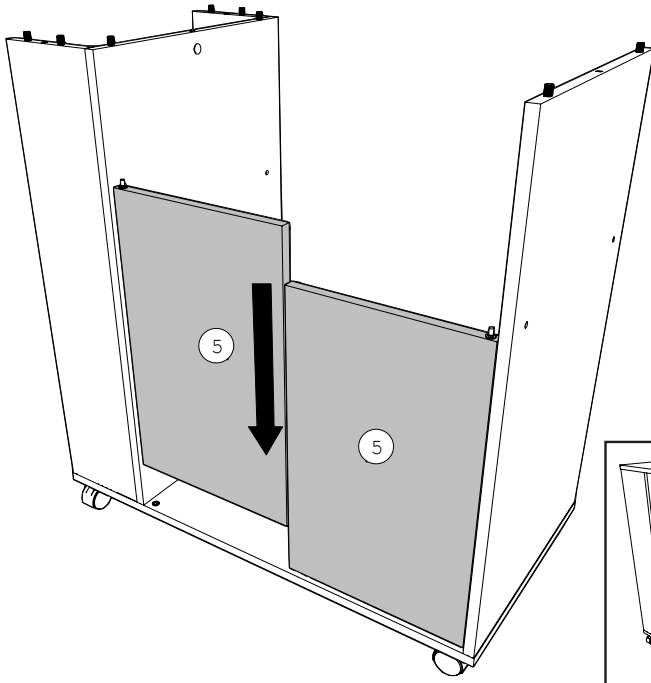
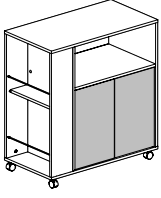

9

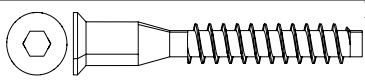

HWHV

x4





x1

WA

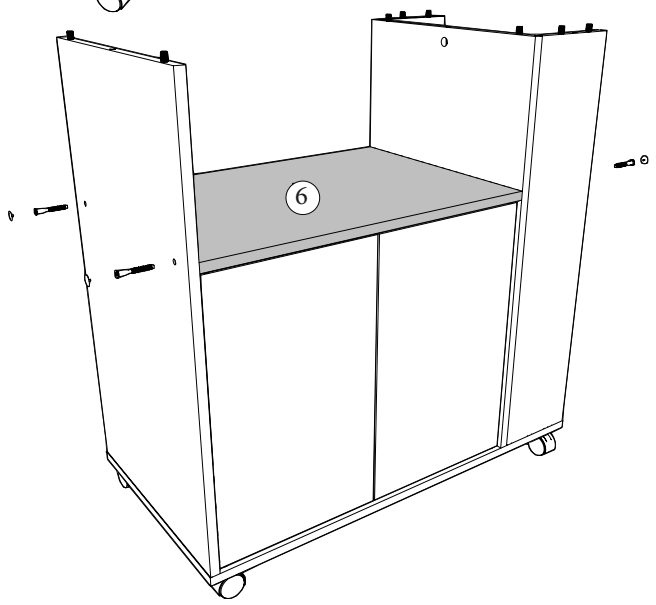
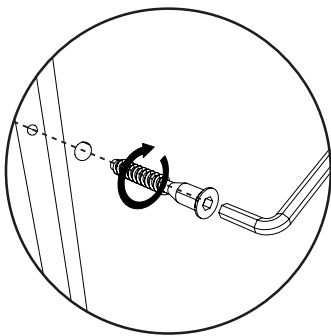
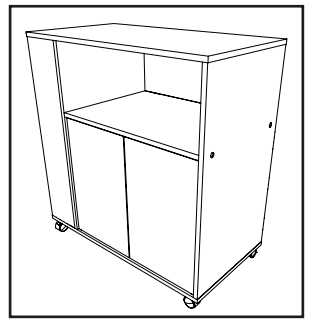
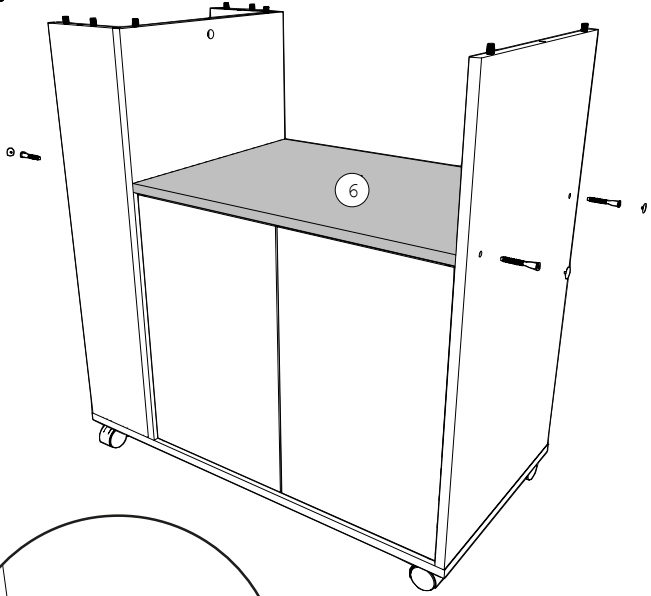
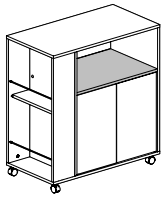

x4



10 AI  x4

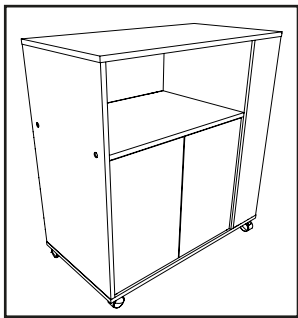
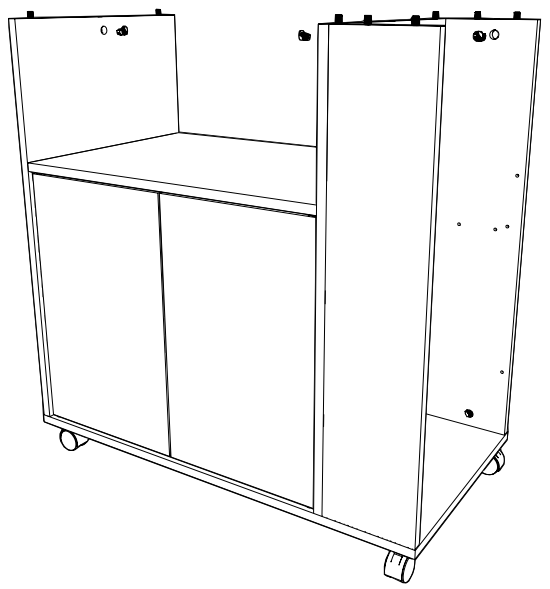
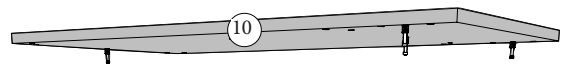
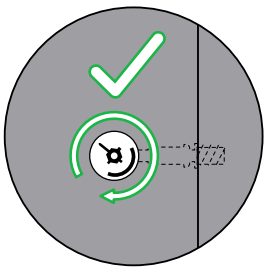
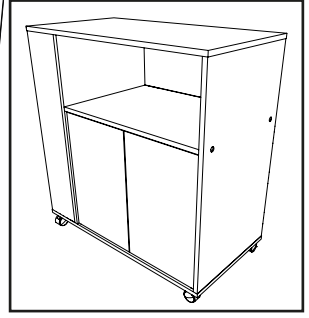
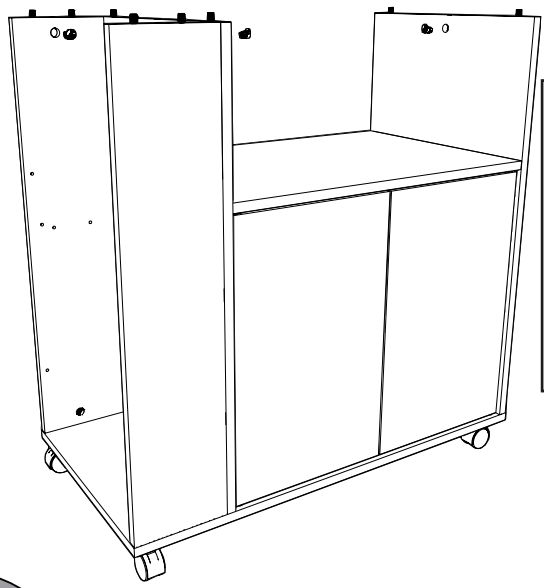
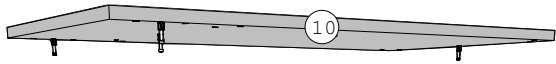
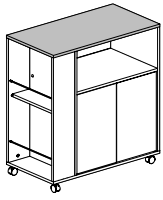

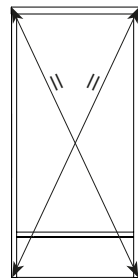
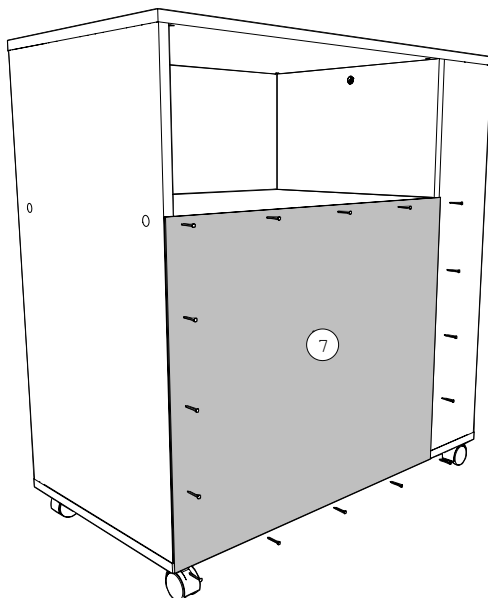
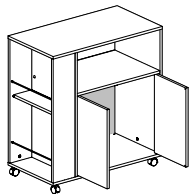
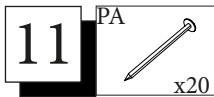

FR- Mesurer les diagonales du meuble pour vérifier l'équerrage. La mesure doit être identique.

EN- Measure the diagonals of the piece of furniture to check for straightening. The measurement must be identical.

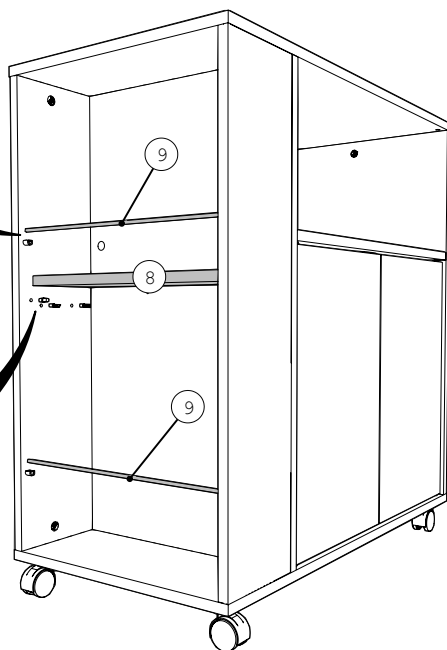
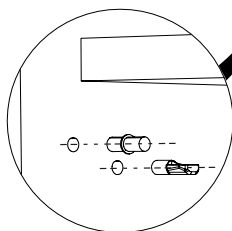
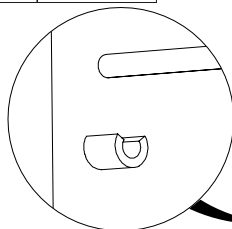
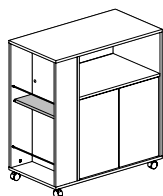
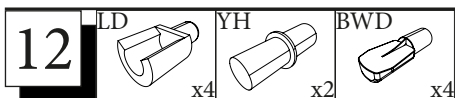

13

PB

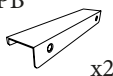

x2



VG

x4

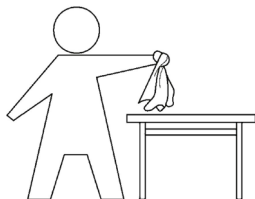
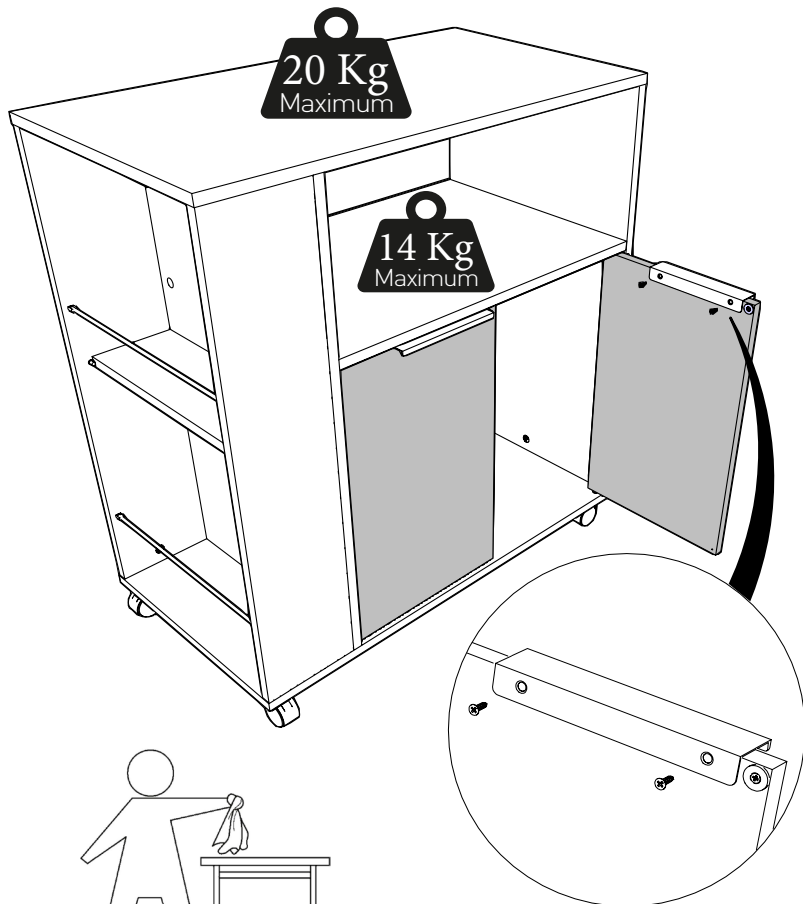
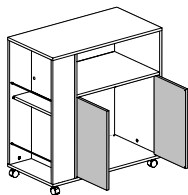

FR: INSTRUCTIONS GÉNÉRALES POUR LE MOBILIER CONSTITUÉ DE BOIS OU DE COMPOSITES DE BOIS (COMME LES SURFACES EN MELAMINÉ, STRATIFIÉ OU PLACAGE)

Nettoyer à l'aide d'un chiffon humide. Utiliser uniquement de l'eau ou un détergent doux.
Essuyer à l'aide d'un chiffon propre.

EN: GENERAL INSTRUCTION FOR FURNITURE MADE OF WOOD OR WOOD COMPOSITES SUCH AS MELAMINE, LAMINATE OR VENEER SURFACES!

Wipe clean with a damp cloth. Use only water or a gentle detergent.
Wipe dry with a clean cloth.



LE TRI
+ FACILE



FR

**Pensez à
donner ou recycler.**



OU



OU



Association Magasin Déchèterie

<https://quefairedemesdechets.fr>